

Kohler® Diesel

Model KD425-2

2 Cylinders » 851 cc » 14 kW/18.8 HP » 3600 RPM » 31 ft. lbs. @2200 RPM

Certification

EPA TIER 2 ■
ECE R 24-03 ●

Features

- 4-Stroke Air-Cooled Diesel Engine
- Direct Fuel Injection
- Flywheel Fan Air Cooling
- Mechanical Fuel Feeding Supplement
- Full-Pressure Lubrication with Oil Pump
- Full-Flow Oil Filter
- Automatic Mechanical Fuel Supplement
- Variable Speed Governor
- Aluminum Crankcase
- 12 V Electric Starter
- Counter-Clockwise Rotation (PTO Side)
- Aluminum Alloy Independent Heads
- Reborable Independent Cast-Iron Cylinders

Applications

- Power Buggy
- Vibrating Roller
- Generator
- Welder
- High-Pressure Cleaner
- Hydraulic Power Pack
- Agricultural Pump
- Two-Wheel Tractor

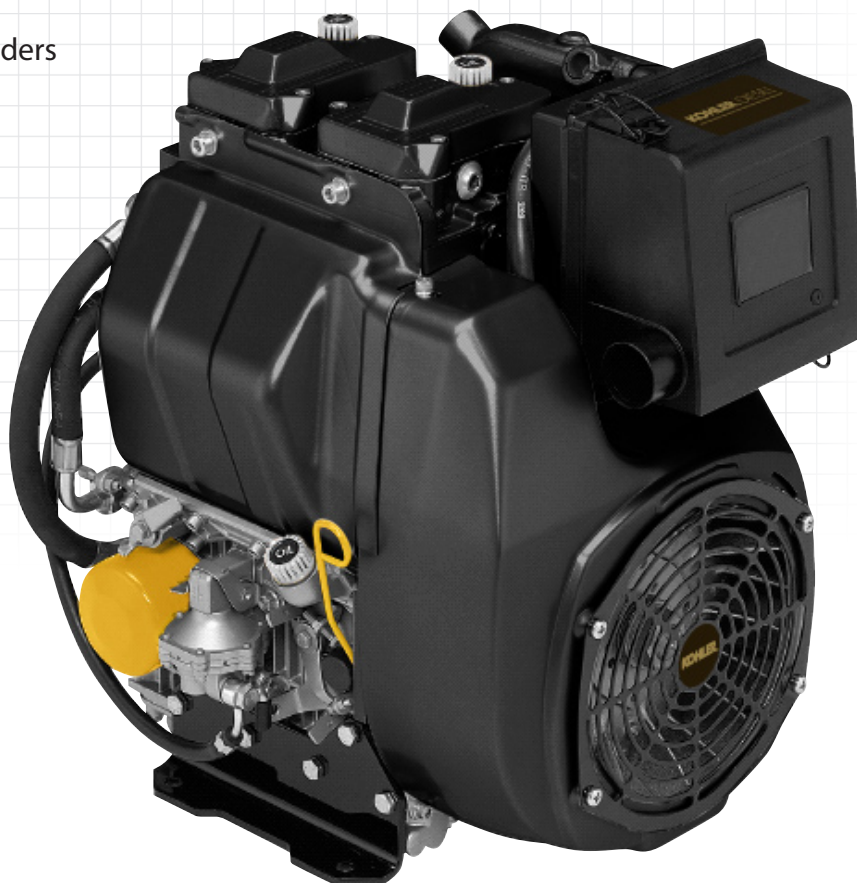

Kohler® Diesel

Model KD425-2

Specifications

Cylinders	No. of Cylinders	2	
Displacement	cc/cu. in.	851/51.9	
Bore	mm/in.	85/3.3	
Stroke	mm/in.	75/3	
Compression Ratio		19:1	
Rating kW/HP	N (80/1269/CEE) ISO 1585	14/18.8	
	NB ISO 3046 IFN	13/17.4	
	NA ISO 3046 ICXN	12/16.1	
Max. Torque	N·m/ft. lbs. @ 2200 RPM	42/31	
Max. Torque 3 PTO	N·m/ft. lbs.	18.0/13.3	
Counter-clockwise Rotation			
Engine Speed - 3 PTO Ratio		1:0.87	
Minimum Idling Speed RPM		1000	
Fuel Tank Capacity	liters/quarts	4/4.2	
Oil Consumption	kg/h/lb/h	0.0085/0.0187	
Oil Capacity	liters/quarts	1.8/1.9	
Min. Allowable Oil Pressure	bar/psi	0.8/11.6	
Max. Allowable Angle of Operation (Peak Values)		25° (35°)	
Volume of Air Required for Correct Combustion @ 3600, 3000 RPM	liters/min/cfm	1330,1110/47,39	
Volume of Air Required for Correct Cooling @ 3600, 3000 RPM	liters/min/cfm	14200,11835/501,418	
Dry Weight	kg/lb	53/116.8	
Recommended Battery	V/Ah	12/55	
Axial Load	(Continuous)	kg/lb	100/200
	(Intermittent)	kg/lb	300/661

Minimum Pulley Diameters for Belt Drive

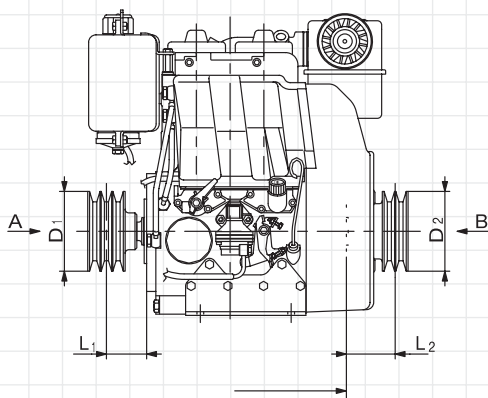

$$D_1 \text{ (mm)} \geq 700 [45 + L_1 \text{ (mm)}] \frac{N \text{ (kW)}}{n \text{ (RPM)}}$$

$$D_2 \text{ (mm)} \geq 1540 [17 + L_2 \text{ (mm)}] \frac{N \text{ (kW)}}{n \text{ (RPM)}}$$

Max. allowable axial load in both directions A-B = 300 kg/661 lb_f

Sound Pressure Level dB (A)

Sound Pressure Level Polar Diagram
Open Field at 7 Meters - No Load
Running Engine.

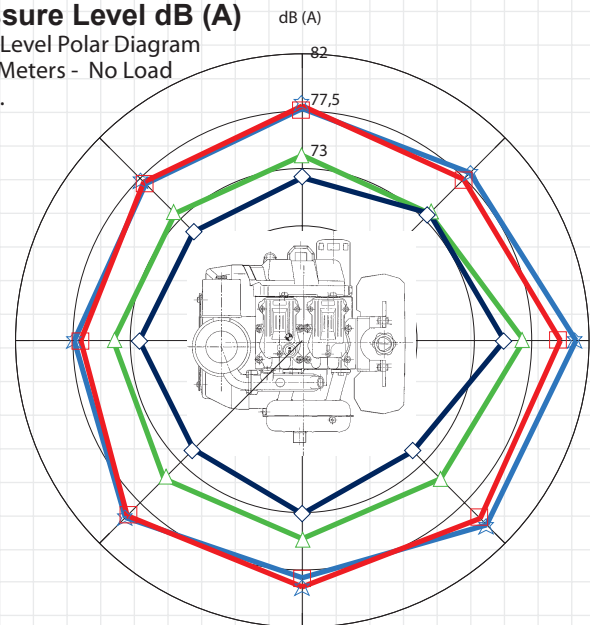

1500 RPM 2000 RPM 2500 RPM 3000 RPM

Kohler® Diesel Model KD425-2

Curves

KD425-2 @ 3600 RPM ■

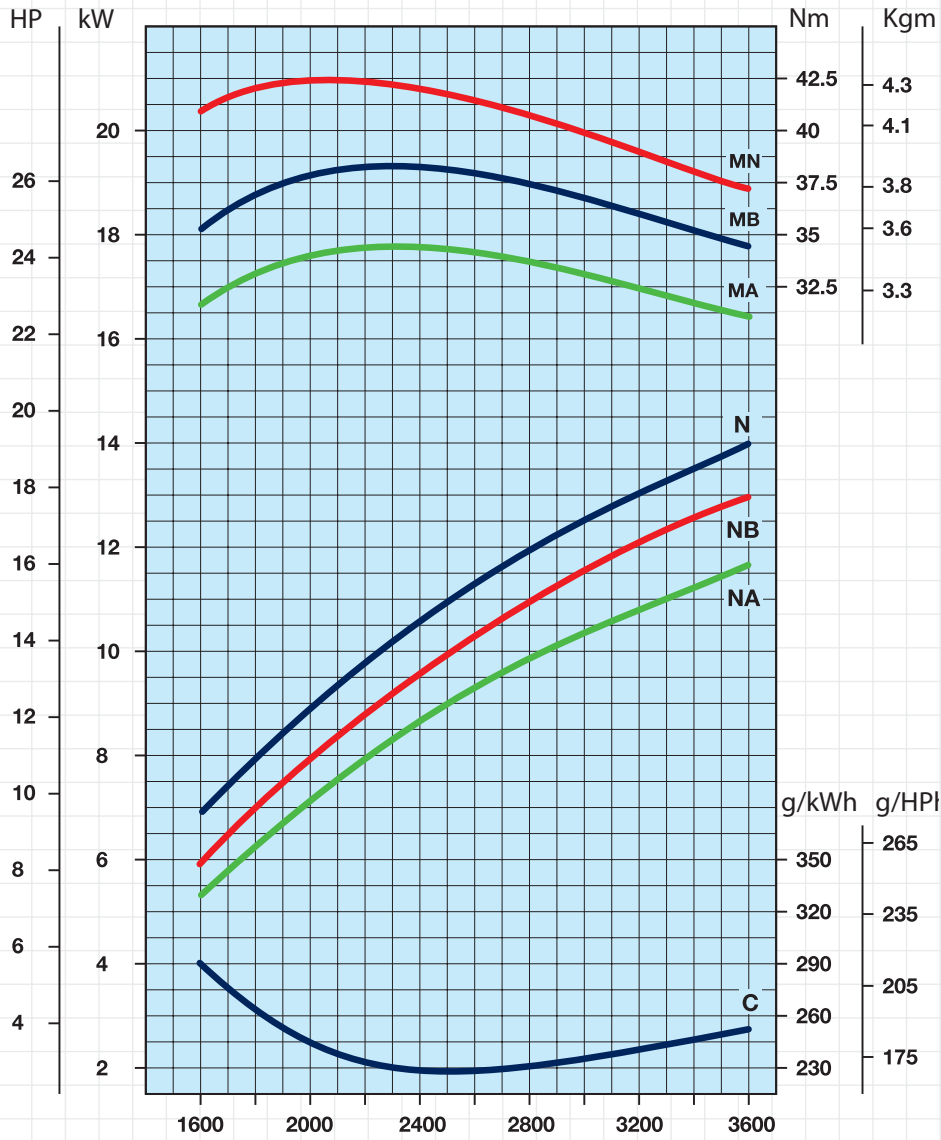

- N Power Curve - 80/1269/CEE - ISO 1585 -
- NB Power Curve - ISO 3046/1 - IFN -
- NA Power Curve - ISO 3046/1 - ICXN -
- MN Torque Curve - (N curve)
- MB (B Curve) - MA (A curve)
- C Specific Fuel Consumption - (NB curve)

Output Power for Fixed Speed
Application (Including Generators)

Engine Power kW

RPM	Intermittent (NB)	Continuous (NA)
3600	13.0	12.0
3000	11.5	10.5

Kohler® Diesel Model KD425-2

Technical Drawings

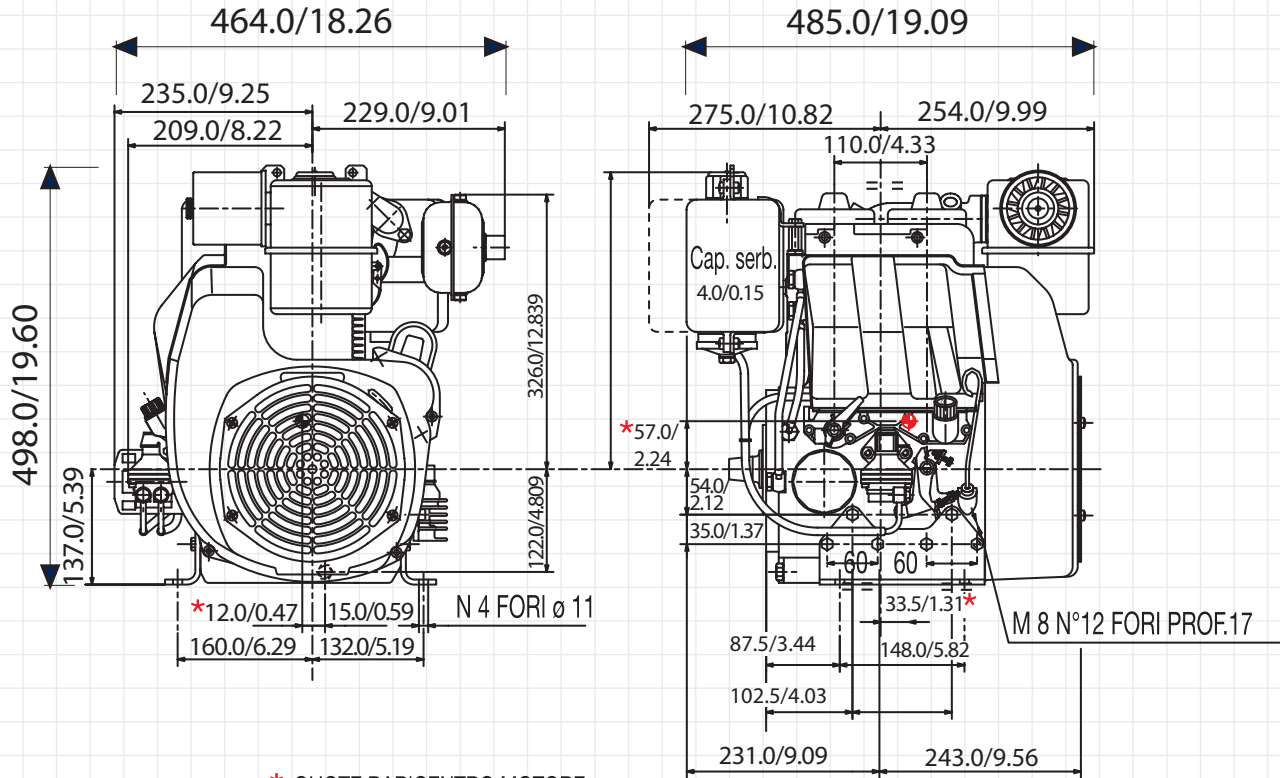

* QUOTE BARICENTRO MOTORE
GRAVITY CENTER OF THE ENGINE

Standard Equipment

- Electric Starter with 12 V Alternator
- Remote Throttle
- Dry Type Air Filter with Prefilter
- External Oil Filter
- Oil Pressure Switch
- 1-1/8" Dia. Keyed Integral Crankshaft with 7" Mtg. Flange
- Downward Muffler Angled Towards Flywheel End
- Engine Feet
- Power Take-Off on Crankshaft
- Keyswitch Panel
- Fuel Lift Pump
- Counter-Clockwise Rotation (PTO Side)
- Automatic Extra Fuel Device
- Oil Cooler

Accessories

- Extended Wiring Harness
- 1" Threaded Pump with Integral Crankshaft
- SAE 2A-9T Hydraulic Pump Adapter
- SAE J609a Ext 6 Crankshaft with Metric Type B Mtg. Flange

